



## Residential Electric Water Heaters

**6-Year Tank Warranty • 6-Year Parts Warranty**



**TABLE TOP**

**Table Top Electric Water Heaters features convenient flat surface at 36" height, providing extra "counter space" wherever installed.**

All plumbing and electrical connections are made through back of water heater. 27 and 40-gallon tank capacities. Equipped with PEXAN™ cross-link PEX polymer dip tube.

**Junior Electric Water Heaters feature compact design, side-mounted plumbing and electrical connections.** Designed for installation under a counter, in a crawl space or in other tight spaces. Tank capacities from 6 through 40 gallons. Single heating element standard.



**JUNIOR**

**Point-Of-Use Electric Water Heaters designed for low-demand point-of-use applications, such as lavatories in offices, or any building with remote restrooms.** 2-gallon and 4-gallon tank capacities, with single heating element.

Includes 110/120V cord set with 3-prong plug (optional on 240V) models. Also includes wall-mounting brackets for easy installation.

**All Select Specialty Electric Water Heaters equipped with factory-installed Temperature & Pressure (T&P) Relief Valve and foam insulation to protect against radiant heat loss.**



**POINT-OF-USE**

**Code Compliance** – All models meet or exceed federal minimum energy standards effective January 20, 2004, according to latest editions of the National Appliance Energy Conservation Act (NAECA). They also comply with the latest editions of the B.O.C.A. National Codes, C.E.C., U.B.C., S.B.C.C., C.A.B.O. and the H.U.D. standards. All models U.L. Listed according to safety specifications outlined in Underwriters' Laboratories, Inc. Standards for Safety (U.L. 174).



For Additional Technical Information,  
**PHONE 800-365-0024**

STATE WATER HEATERS  
500 Lindahl Parkway, Ashland City, TN 37015  
[www.statewaterheaters.com](http://www.statewaterheaters.com)

 **state**  
WATER HEATERS  
*The Expert's Choice<sup>®</sup>*

## Residential Electric Water Heaters

### 6-Year Tank Warranty • 6-Year Parts Warranty

MODEL NUMBER	PEAK DEMAND OUTPUT (1st Hour Rating Gallons)	ENERGY FACTOR	GALLON CAPACITY	ELEMENT WATTAGE		RECOVERY 90°F RISE	R VALUE	DIMENSIONS IN INCHES			APPROXIMATE SHIPPING WEIGHT (LBS.)
				STANDARD 240V	MAXIMUM 240V			A HEIGHT	B	C DIAMETER	
<b>TABLE TOP MODELS</b>											
P6 30 20T1	45	.89	27	4500	6000	21	12	36	25	21	141
P6 40 20T4 W	52	.88	40	4500	6000	21	12	36	25	24	174
MODEL NUMBER	PEAK DEMAND OUTPUT (1st Hour Rating Gallons)	ENERGY FACTOR	GALLON CAPACITY	ELEMENT WATTAGE		RECOVERY 90°F RISE	R VALUE	DIMENSIONS IN INCHES			APPROXIMATE SHIPPING WEIGHT (LBS.)
				STANDARD 120V	MAXIMUM 240V			A HEIGHT	B	C DIAMETER	
<b>JUNIOR MODELS</b>											
P6 6 10MS K	N/A	N/A	6	1650	3800	8	8	17-1/4	12-1/2	14	42
P6 10 10MS K	N/A	N/A	10	1650	4500	8	8	17-1/4	12-1/2	16	53
P6 17 10MS K	N/A	N/A	17	1650	4500	8	8	28	21-1/2	18	71
P6 20 10MS K	N/A	N/A	19.9	1650	4500	8	8	21-3/4	16-1/2	20	75
ES6 30 SOMS K	37	.93	29	1650	6000	8	16	30	22-1/2	22	111
ES6 40 SOMNS K	43	.92	38	1650	6000	8	12	31-1/8	24-5/8	23	125
<b>POINT-OF-USE MODELS</b>											
ES6 2 SSUS K †	N/A	N/A	2	1440 @ 120V *		7	8	12-3/4	N/A	10	21
ES6 4 SSUS K †	N/A	N/A	4	1440 @ 120V *		7	8	20	N/A	10	27

Recoveries are rounded to nearest gallon

Water Connections – 3/4" on Table Top and Junior models, 1/2" NPT on Point-of-Use models

\*Also available in 240V, with 1500 watt element. For 240V, change "K" to "E" in model number (ES6 2 SSUS E)

†Top mounted T&P adds approximately 3" additional to overall height

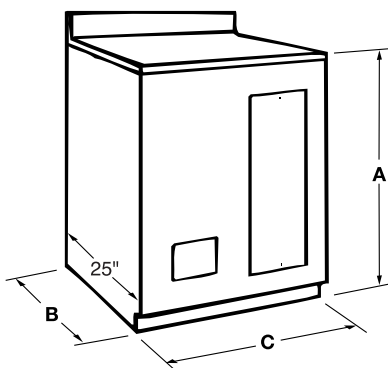
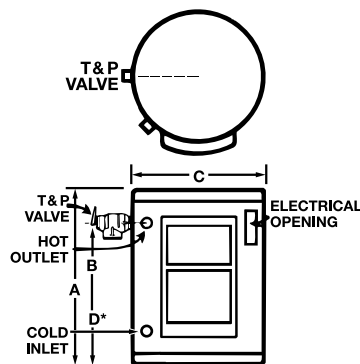
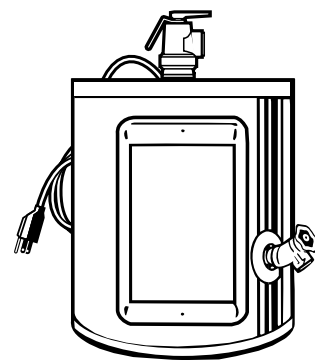

TABLE TOP MODELS



JUNIOR MODELS

\*D Dimension from floor to T&P valve  
(D Dimension is the same dimension as B)



POINT-OF-USE MODELS

For complete information on limited warranties, consult written warranty, or contact the State Customer Care Center, 1-800-365-0024.

State Industries, Inc. reserves the right to make product changes or improvements without prior notice.

For Additional Technical Information,  
PHONE 800-365-0024

STATE WATER HEATERS  
500 Lindahl Parkway, Ashland City, TN 37015  
www.statewaterheaters.com

The Expert's Choice<sup>®</sup>